

## **! WARNING**

To reduce the risk of drowning, falls, paralysis, electrocution, or other serious injury or death:

**Dealer/Installer:** Give manual to homeowner.

**Installer:** Read “**Safe Installation**” on page #2 and all instructions before beginning. For proper assembly and installation, instructions must be followed completely.

**Homeowner:** Read “**Safe Use**” on back cover before using. Save these instructions. Installation must comply with local codes and may require permits.

# THE STORAGE STEP

## By Confer Plastics®

**WEIGHT LIMIT 300 LBS.**

**ASSEMBLY, INSTALLATION AND USE MANUAL**

Assembly video available online: [www.conferplastics.com](http://www.conferplastics.com)



**Scan to  
see our  
Installation  
Videos**



**MODEL #LASS36-SC**



MADE IN U.S.A. BY

**CONFER**  
*plastics inc.®*

[www.conferplastics.com](http://www.conferplastics.com)



# THE STORAGE STEP

If missing parts call - Toll free U.S./Canada - 800-635-3213 or [www.conferplastics.com](http://www.conferplastics.com)

## Parts List

- 2 - 36" Treads
- 1 - 7" Support
- 1 - 5" Support
- 1 - 3" Support
- 1 - Storage Liner
- 2 - Sidewalls

## Hardware Pack

- 2 - Stainless Steel Hinges
- 1 - 1 Foam Strip (4 pads)
- 4 - #10 x 1-1/4" self-tapping screws
- 8 - #10 x 3/4" self-tapping screws

## Tools Needed

- Rubber Mallet
- Cordless Drill
- 1/8" Drill Bit
- #2 Phillips head driver

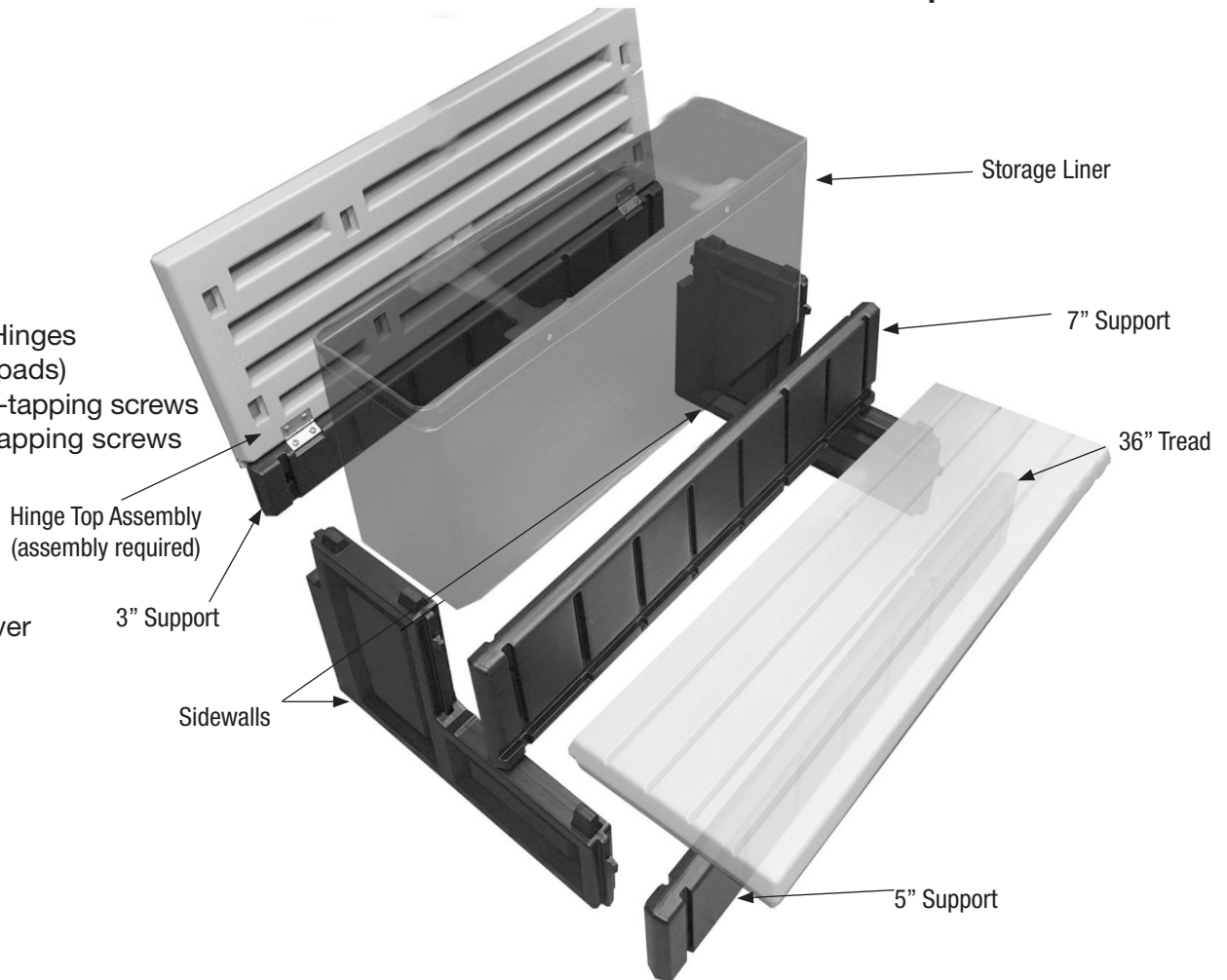

## Safe Installation

### ⚠ WARNING

To reduce the risk of drowning, electrocution, falls, or other serious injury or death:

**Check building codes/permitting** - Consult your local Building Department before installation of your step and equipment. Equipment installation must comply with the codes of the authority having jurisdiction and may require permits (e.g., building, plumbing, electrical, zoning, etc.). Be sure that barriers (fences, gates, etc.) restricting spa access meet local codes.

**Use for intended purpose only** - Not intended for storing hazardous products (e.g., chemicals) - the step is not a secure location.

**Check that you have all required parts** - Check the contents of the carton with the Parts List for this step. All parts and hardware are required. If any parts are missing **DO NOT attempt to assemble or install the step**. Instead call Toll Free U.S. 800-635-3213 or visit our website at [www.conferplastics.com](http://www.conferplastics.com) for assistance.

**Select an appropriate location** - The step must be located on a level solid base and in a location that will be in full view of competent adult supervision when in use.

**- Follow all instructions.**

- For stable correct assembly and installation all instructions must be followed completely and in the sequence shown.
- Follow the manufacturer's recommendations for the safe use of all hand tools and equipment used during installation.

**Cordless drill only. No corded drills near water** - Use a cordless drill for assembly and installation. To reduce the risk of electrocution, NEVER use a corded drill in or around a water.

**Lift safely** - When lifting awkward or heavy loads, have another person help you.

**Double check after installation -**

- Before using the product, after assembly and installation, go over the instructions and procedures again to make sure nothing has been overlooked.

# STEP ASSEMBLY:

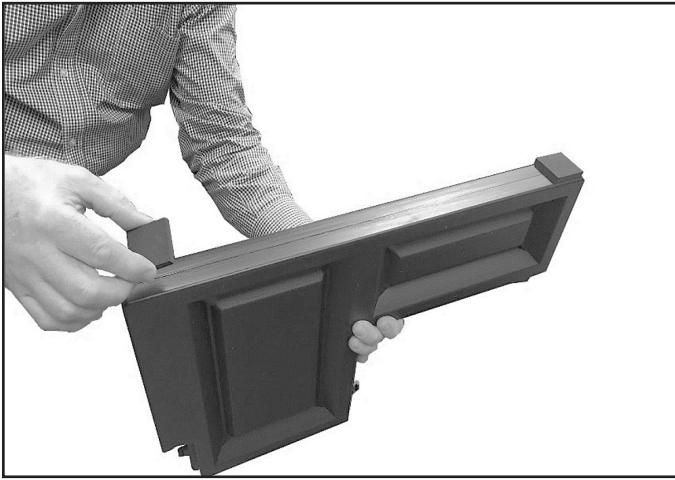

#1: Install 2 self-adhesive pads on each of the sidewalls.

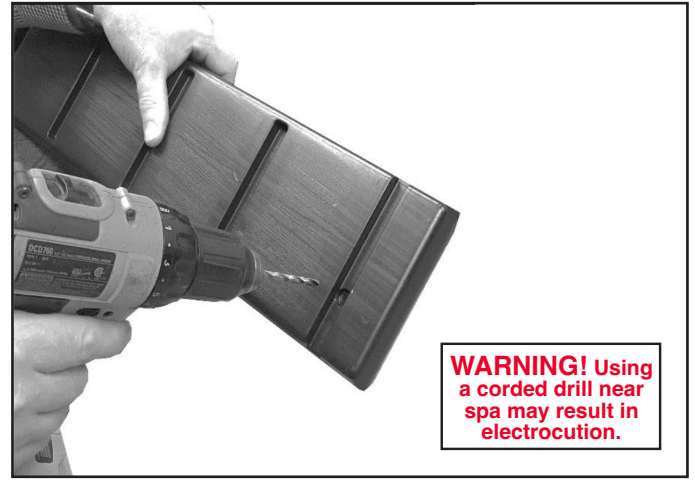

#2: Pre-drill 1/8" pilot holes in the two marked locations at the end of the 5" support.



#3: With a helper, place the 5" support over the two locking tabs on the sidewalls. Tap down with mallet until seated on the locking tabs. Secure the support at both ends using 2 - #10 x 1-1/4" screws.

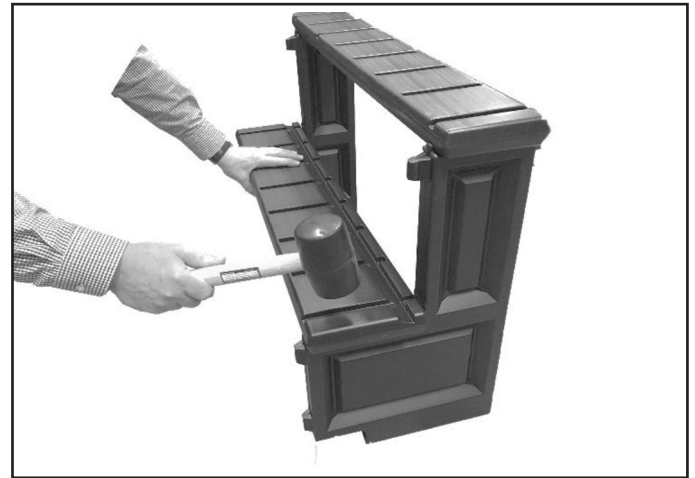

#4: Place the 7" support over the two locking tabs with the groove facing up. Tap down with a rubber mallet until seated on the locking tabs. **No screws are required.**

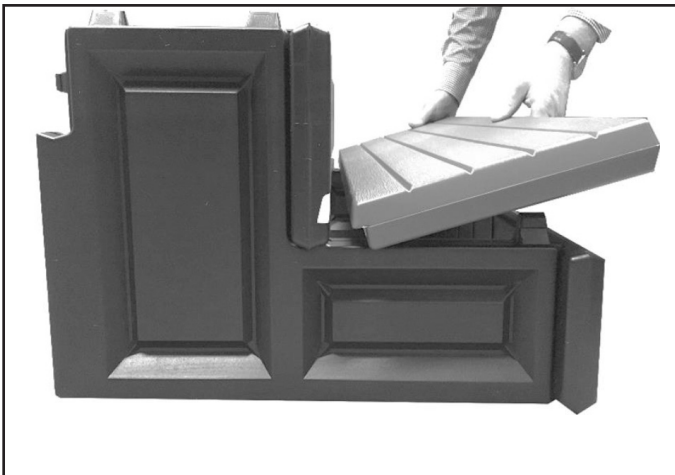

#5: To install the bottom tread, place the tapered edge into the groove on the 7" riser. Apply pressure to force the tapered edge into the groove. While holding the tread in place, have your helper tap the front of the tread with the rubber mallet. This will help seat the tread into the groove. Tap down on top of the tread until seated on the locking tabs.





**#6:** Place hinge (barrel side up) over the mortised area on the 3" support. Attach using 2 - #10 x 3/4" self-tapping screws through the indents on the support. It is not necessary to drill pilot holes. Repeat to attach second hinge.

**\*NOTE\*: HINGES MUST BE INSTALLED BARREL SIDE UP FOR STEP TO CLOSE PROPERLY**



**#7:** Position the second tread on a flat surface bottom side up. Place the hinges over the mortised area on the treads and attach using 2 - #10 x 3/4" self-tapping screws in each hinge.



**#8:** Stand the step up on the front edge. While holding, have your helper place the hinged top assembly support over the locking tabs on back of the step. Tap down until seated onto the locking tabs.

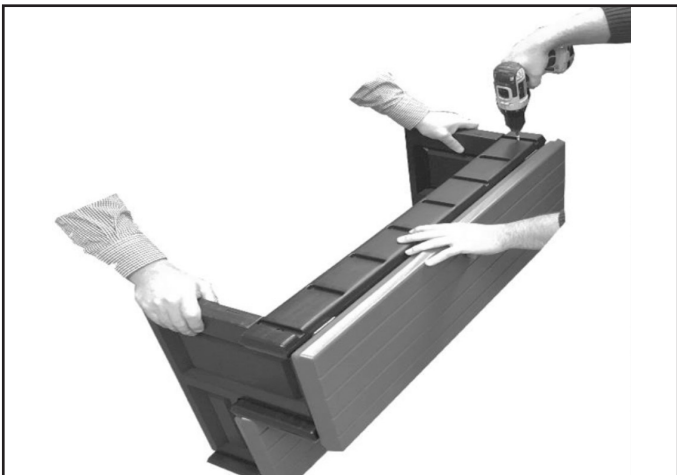

**#9:** Pre-drill 1/8" pilot holes in the two marked locations at the ends of the 3" support. Attach support using 2 - #10 x 1-1/4" self-tapping screws.

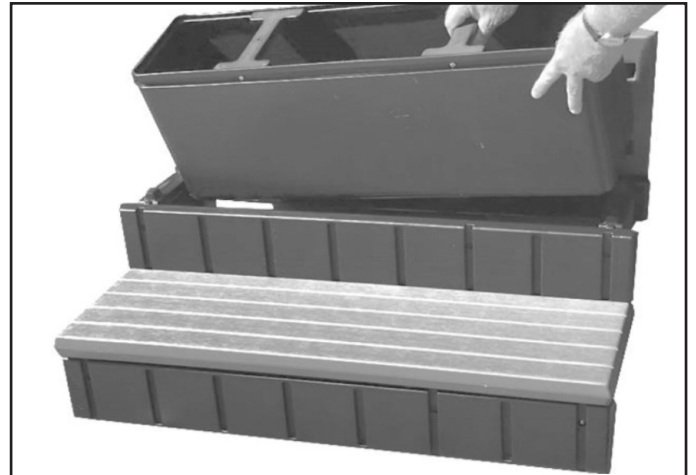

**#10:** Place storage liner into step.

## Safe Use

### **⚠️ WARNING**

To reduce the risk of drowning, falls, paralysis, electrocution, or other serious injury or death:

**Use step system properly.**

**Use for intended purpose only** - Not intended for chemical storage.

- **No diving or jumping from steps** - shallow water; risk of paralysis or death.
- ONE PERSON ON THE LADDER/STAIR AT A TIME.
- Illuminate the steps when using the spa at night.

**Weight limit - 300 lbs. maximum** - Exceeding maximum weight may cause the step to fail.

**Secure the spa when not in use** - (for example, with a locked cover or secure gate) - refer to local codes.

**Watch children at all times** when they are in or around water to help prevent drowning.

**BE SURE AND SAFE** - The manufacturer **IS NOT** responsible for improper assembly, installation and use.

## CONFER PLASTICS INC.® FIVE YEAR WARRANTY

Confer Plastics Inc.® warrants their swimming pool ladders and spa products to be free from defects in workmanship for five years from date of purchase.

### DO NOT RETURN DEFECTIVE PART TO DEALER

E-MAIL CONFER PLASTICS AT: **CUSTOMERSERVICE@CONFERPLASTICS.COM**  
A PICTURE [S] OF DEFECTIVE PART, A BRIEF DESCRIPTION OF PROBLEM,  
PROOF OF PURCHASE AND YOUR CONTACT INFORMATION.

INFORMATION MAY ALSO BE FAXED TO CONFER PLASTICS AT: **716-694-3102**  
OR MAILED TO THE ADDRESS BELOW. UPON REVIEW OF THE INFORMATION YOU  
WILL BE NOTIFIED IF PART IS COVERED UNDER THE WARRANTY AND  
THE SHIPPING/HANDLING CHARGES.

This warranty gives you specific legal rights, and you may also have other rights which may vary from state to state.

Confer Plastics Inc.®  
97 Witmer Road  
North Tonawanda, N.Y. 14120-2421

[www.conferplastics.com](http://www.conferplastics.com) © Confer Plastics, Inc.® 2024

MADE IN THE USA



**CONFER**  
*plastics inc.®*

Printed in USA

© Confer Plastics, Inc.® 2024

97 Witmer Road  
North Tonawanda, New York 14120-2421  
Toll Free U.S. 800-635-3213  
FAX 716-694-3102  
[www.conferplastics.com](http://www.conferplastics.com)

REV. 3/24

# Flexible Spa Panel Kit

## REPLACEMENT SPA SKIRTING

Available in 3 colors:



LBG-GRAY



BL-BLACK

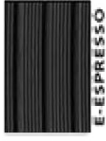

E-ESPRESSO

Model # FSP



Before



After

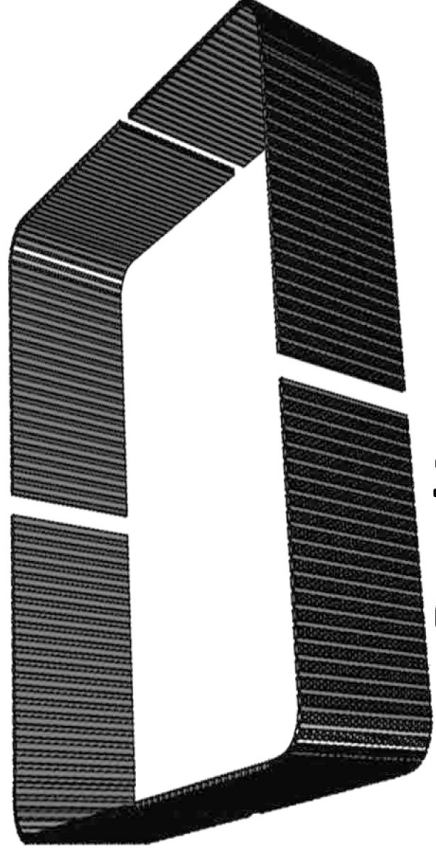

Panel Layout

Now Available!